

Centre Scientifique et
Technique du Bâtiment

84 avenue Jean Jaurès
CHAMPS-SUR-MARNE
F-77447 Marne-la-Vallée Cedex 2

Tél. : (33) 01 64 68 82 82

Fax : (33) 01 60 05 70 37

**European Technical
Assessment**

**ETA-11/0487
of 24/03/2020**

(English language translation, the original version is in French language)

General Part

Nom commercial
Trade name

SORMAT LYT

Famille de produit
Product family

Cheville à clou pour fixation de système composite d'isolation thermique extérieure dans le béton et la maçonnerie
Nailed-in anchor for fixing of external insulation composite systems with rendering in concrete and masonry

Titulaire
Manufacturer

SORMAT OY
Harjutie 5
FIN-21290 Rusko
Finlande

Usine de fabrication
Manufacturing plants

Sormat plant 9

Cette évaluation contient:
This assessment contains

9 pages incluant 6 annexes qui font partie intégrante de cette évaluation
9 pages including 6 annexes which form an integral part of this assessment

Base de l'ETE
Basis of ETA

DEE 330196-01-0604
EAD 330196-01-0604

Cette évaluation remplace:
This assessment replaces

ETE-11/0487 délivrée le 13/12/2016
ETA-11/0487 issued on 13/12/2016

Translations of this European Technical Assessment in other languages shall fully correspond to the original issued document and should be identified as such. Communication of this European Technical Assessment, including transmission by electronic means, shall be in full. However, partial reproduction may be made, with the written consent of the issuing Technical Assessment Body. Any partial reproduction has to be identified as such.

Specific Part

1 Technical description of the product

The SORMAT LYT anchor consists of a plastic expansion sleeve with a collar for fixing the profiles for thermal insulation systems and a metallic nail as expansion element. The anchor sleeve is made of polyamide 6 (PA6) and the nail is made of steel, with bright passivated coating, or made of stainless steel. The collar exists in two different shapes (countersunk or pansunk head). The plastic sleeve is expanded by hammering in the expansion element which presses the sleeve against the wall of the drilled hole.

The installed anchor is shown in Annex A.

2 Specification of the intended use

The anchor is to be used as multiple fixing for the anchorage of profiles for external thermal insulation composite system (ETICS) in concrete and masonry.

The performances given in Annex C are only valid if the anchor is used in compliance with the specifications and conditions given in Annex B.

The provisions made in this European Technical Assessment are based on an assumed working life of the anchor of 25 years. The indications given on the working life cannot be interpreted as a guarantee given by the producer, but are to be regarded only as a means for choosing the products in relation to the expected economically reasonable working life of the works.

3 Performance of the product

3.1 Mechanical resistance and stability (BWR 1)

For Basic Requirement Mechanical Resistance and Stability (BWR1) the same criteria are valid as for Basic Requirement Safety in use.

3.2 Sécurité en cas d'incendie (BWR 2)

EAD 040083-00-04 and ETAG 017 are relevant.

3.3 Hygiene, health and environment (BWR 3)

Regarding dangerous substances contained in this European Technical Assessment, there may be requirements applicable to the products falling within its scope (e.g. transported European legislation and national laws, regulations and administrative provisions). In order to meet provisions of the regulation (EU) No 305/2011, these requirements need also to be complied with, when they apply.

3.4 Safety in use(BWR 4)

Essential characteristic	Performance
Characteristic resistances in concrete and masonry	See Annex C1
Displacements	See Annex C1
Installation distances and dimensions of members	See Annex B2

3.5 Protection against noise (BWR 5)

Not relevant.

3.6 Energy economy and heat retention (BWR 6)

Not relevant.

3.7 Sustainable use of natural resources (BWR 7)

For the sustainable use of natural resources no performance was determined for this product.

3.8 General aspects relating to fitness for use

Durability and Serviceability are only ensured if the specifications of intended use according to Annex B1 are kept.

4 Assessment and verification of constancy of performance (EVCP)

According to the Decision 97/463/EC of the European Commission , as amended, the system of assessment and verification of constancy of performance (see Annex V to Regulation (EU) No 305/2011) given in the following table apply.

Product	Intended Use	Level or Class	Systeme
Nailed-in plastic anchor for fixing of external thermal insulation composite systems	Nailed-in plastic anchor for fixing of external thermal insulation composite systems with rendering on concrete and masonry	—	2+

5 Technical details necessary for the implementation of the AVCP system

Technical details necessary for the implementation of the Assessment and verification of constancy of performance (AVCP) system are laid down in the control plan deposited at Centre Scientifique et Technique du Bâtiment.

The manufacturer shall, on the basis of a contract, involve a notified body approved in the field of anchors for issuing the certificate of conformity CE based on the control plan.

Issued in Marne La Vallée le **24/03/2020** par

La Cheffe de Division
Anca CRONOPOL

The original French version is signed

Scheme of the SORMAT LYT anchor in use:

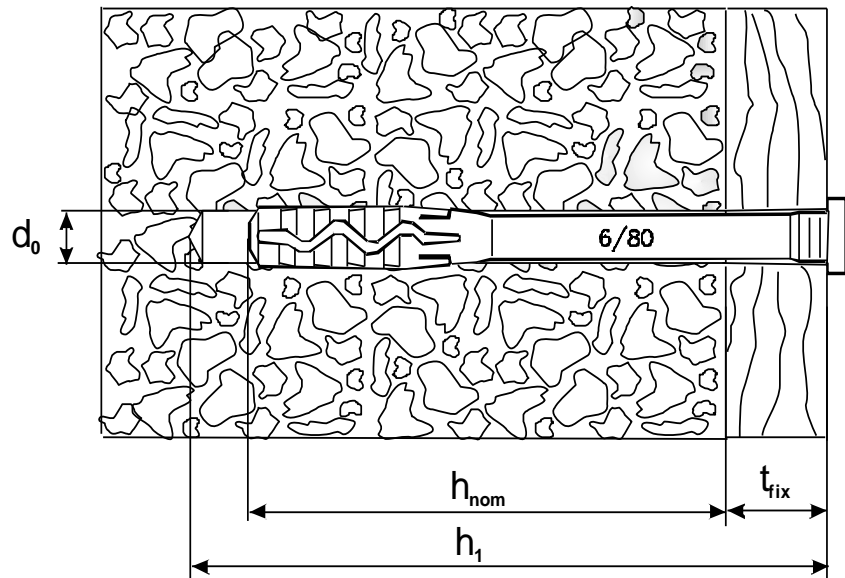

- L : total length of the plastic sleeve
- h_{ef} : effective anchorage depth
- d_0 : drilled hole diameter
- h_0 : depth of drilled hole
- t_{fix} : thickness of fixture
- D : diameter of the collar

t_{fix} , thickness of fixture corresponds to the thickness of the equalizing layer or non loadbearing coating in addition to the thickness of the profile itself.

SORMAT LYT	Annex A1
Description of the product Installed anchor	



SORMAT LYT : Plastic sleeve and steel nail / Marking on plastic sleeve

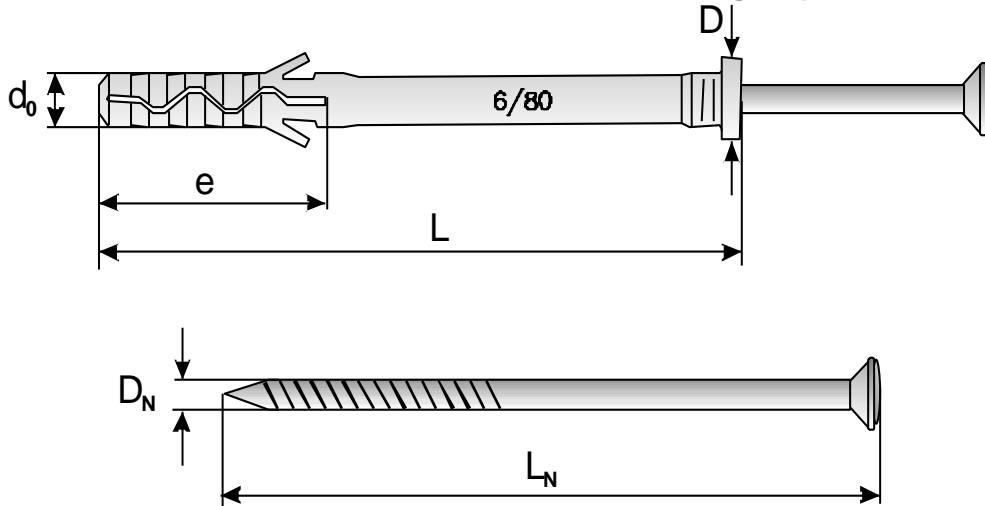

Designation of the anchor : anchor name, anchor diameter, length of the expansion sleeve, collar shape (UK or LK) and type of coating (SP or KP, bright coating). *For example: LYT 6/80 UK KP.*
Marking : the expansion sleeve displays anchor diameter (d_0) / length of the expansion sleeve (L).

Table A1: Different sizes and combinations of plastic sleeves and steel nails

Ø5 pansunk	LYT 5/L LK	
Ø5 countersunk	LYT 5/L UK	
Ø6 pansunk	LYT 6/L LK	
Ø6 countersunk	LYT 6/L UK	
Ø8 pansunk	LYT 8/L LK	
Ø8 countersunk	LYT 8/L UK	

SORMAT LYT

Description of the product

Different components of the anchor : sleeve and nails

Annex A2

Table A2 : Materials

Part	Designation	Material	
1	Plastic expansion sleeve	Polyamide	
2	Nail	Zinc electroplated steel ≥ 5 µm acc. EN ISO 4042	EN ISO 898-1: grade 5.8
		Stainless steel A2	EN 10088: grade 50
		Stainless steel A4	

Table A3 : Dimensions des composants et données d'installation

SORMAT LYT Anchor type (diameter / length)	Maximum thickness of fixture	Diameter of the expansion sleeve and drilled hole	Length of the expansion part	Diameter of the collar	Diameter of the nail	Emb. depth	Depth of the drilled hole	Length of the nail
	t _{fix}	d _{nom} et d ₀	e	D	d _N	h _{ef}	h ₀	L _N
	[mm]	[mm]	[mm]	[mm]	[mm]	[mm]	[mm]	[mm]
5/30	0	5	22	8.3	3,3	30	40	30
5/40	10							40
5/50	20							50
6/40	10	6	28	9.0	3.7			40
6/60	30							60
6/80	50							80
8/60	20	8	35	12.0	4.8	40	50	60
8/80	40							80
8/100	60							100
8/120	80							120

Installation

- The anchor shall be set at a temperature of at least 0°C.
- The drilled hole is realized for concrete and masonry made of clay brick, by means of a hammer drill by impact.
- The expansion sleeve is set into the drilled hole with a hand hammer by way of slight hammering.
- The nail is then hammered into the expansion sleeve, until the head of the nail rests on the plate.

SORMAT LYT

Description of the product
 Dimensions, Material, Installation data

Annex A3

Specifications of intended use

Anchorage subject to:

- Multiple fixing for the anchorage of bonded thermal insulation composite systems (ETICS).

Base materials:

- Use category « A » : Reinforced or unreinforced normal weight concrete, cracked or non-cracked, with strength class \geq C12/15, according to EN 206: 2000-12 ;
- Use category « B » : solid masonry according to Annex B2 ;
- For other base materials of the use categories « A », or « B », the characteristic resistance of the anchor may be determined by job site tests according to TR 51, Edition May 2016 (EOTA).

Design:

- The design of anchorages is carried out in compliance with EAD 330196-00-0604 (June 2016), "Plastic anchors for fixing of external thermal insulation composite systems with rendering" under the responsibility of an engineer experienced in anchorages.
- Verifiable calculation notes and drawings shall be prepared taking account of the loads to be anchored, the nature and strength of the base materials, the thickness of insulation and the dimensions of the anchorage as well as of the relevant tolerances.
- Proof of direct local application of load on the base material shall be delivered.
- The anchor shall only be used for the transmission of wind suction loads. All other loads such as dead load and restraints shall be transmitted by the adhesion of the relevant external thermal insulation composite system.
- The anchor with the bi-chromated steel nail shall be used with a thermal insulation cover of at least 50mm

Installation:

- Anchor installation carried out by appropriately qualified personnel and under the supervision of the person responsible for technical matters on the site.
- Use of the anchor only as supplied by the manufacturer without exchanging the components of an anchor.
- Anchor installation in accordance with the manufacturer's specifications and drawings prepared for that purpose and using the appropriate tools.
- Checks before placing the anchor to ensure that the characteristic values of the base material in which the anchor is to be placed are identical to the values to which the characteristic loads apply.
- Observation of the drilling method : in the case of horizontally perforated clay bricks, the drilled hole is carried out using a rotary drill. In the case of other base materials covered in this Assessment, the drilled hole is carried out using hammer or impact drilling.
- Placing drill holes without damaging the reinforcement.
- Temperature during installation of the anchor \geq 0°C.
- Exposure to UV due to solar radiation of the anchor not protected by rendering 6 weeks.

SORMAT LYT

Intended Use
Specifications

Annexe B1

Table B1 : Base materials

Base material	Dimensions L x l x H [mm]		References	Compressive strength [MPa]
Concrete C20/25	-		EN 206-1	25
Concrete C50/60	-		EN 206-1	60
Clay brick		220x110x 55	NF EN 771-1	4.7 (bending test)

Table B2 : Minimum spacing and edge distances, dimension of members

Minimum spacing	$S_{\min} \geq 100 \text{ mm}$
Minimum edge distance	$C_{\min} \geq 100 \text{ mm}$
Minimum thickness of member	$h \geq 100 \text{ mm}$

SORMAT LYT

Installation data (concrete and masonry)

Base materials

Minimum thickness, spacing and edge distances

Annex B2

Table C1 : Characteristic resistance to tension loads N_{Rk} in concrete and masonry for a single anchor in kN

Base material	SORMAT LYT		
	Characteristic resistance to tension loads N_{Rk} [kN]		
	Ø5	Ø6	Ø8
Concrete C15/20	0,2	0,4	0,75
Concrete C20/25 à C50/60	0,3	0,6	0,9
Clay Brick	0,2	0,6	0,75

Displacements, when loaded to the design value of resistance:

- in normal weight concrete or in clay brick, a displacement of approximately 0,3 mm in the load direction is expected.

SORMAT LYT	Annex C1
Characteristic resistance to tension loads N_{Rk} in concrete and masonry	